



PLEASE REMOVE THIS TAG!!!!

None of the information presented in these instructions is intended to contradict or supersede the information found in Federal Motor Vehicle Safety Standards #208, 209, 210.

UNIVERSAL INSTALLATION INFORMATION:

All US passenger cars, beginning with 1962 models, have seat belt anchorages for at least two lap belts in the front seat. Since January 1, 1968, vehicle manufacturers have been required to install lap belt anchorages for each front and rear seating position and upper torso belt anchorages at each forward facing outboard seating position. On January 1, 1972, this same requirement became effective for trucks.

IMPORTANT: Where the vehicle manufacturer has made special provisions to attach belts, BE SURE TO USE THOSE FITTINGS.

When you use the manufacturer's threaded floor fittings, it is **IMPORTANT** that all full threads be engaged to obtain the ultimate strength of the anchorage.

NOTICE:

Seat belts should **NOT** be attached to the seat, unless the vehicle manufacturer indicates that the seats and seat mounting systems have been specifically designed to withstand seat belt assembly loads.

GENERAL INSTALLATION INSTRUCTIONS:

1. Mount the short side of the belt on the aisle side.
2. Avoid rough or sharp edges when choosing a belt path.
3. Install the shoulder harness so that, when in use, it will be attached to the lap belt as close as possible to the inboard/aisle side hip.

WHERE NO FACTORY FITTINGS ARE AVAILABLE:

4. If the seat is adjustable, move to the rearmost position.
5. Mark the floor behind the seat to assure that the lap belt is pulling downward and rearward at approximately a 70 degree angle. (See FIGURE 1)

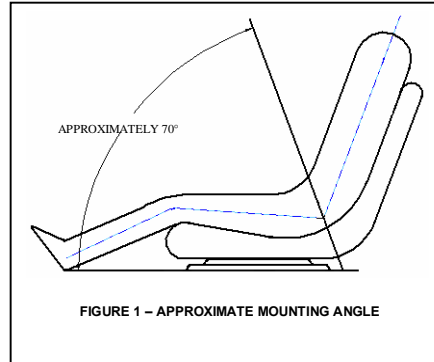

FIGURE 1 – APPROXIMATE MOUNTING ANGLE

6. Space the attachment points 15+ to 25+ apart so that the lap belt forms a U-shaped loop when in use. (See FIGURE 2) Never attach both ends of the same lap belt to the same anchorage or attachment point.

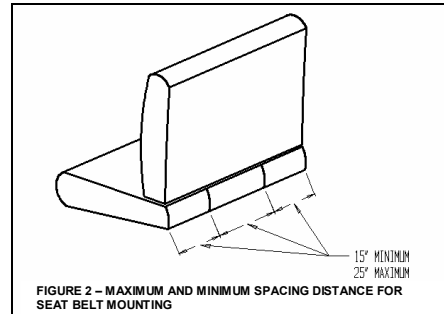
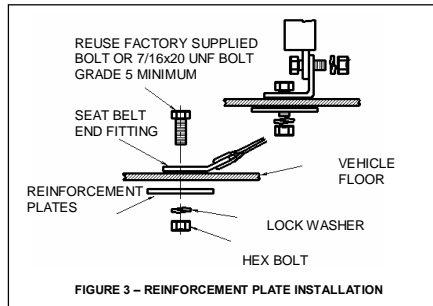

FIGURE 2 – MAXIMUM AND MINIMUM SPACING DISTANCE FOR SEAT BELT MOUNTING

7. Carefully drill holes to avoid damaging the exhaust system and brake or fuel lines. Always use the reinforcement plates (provided with the belt) underneath the floor. (See FIGURE 3) Examine and reinforce any weakened area of the floor pan.



8. **CAUTION: IF THE FIXED END OF A SINGLE SIDE ADJUSTABLE BELT IS TOO LONG TO ALLOW A SNUG FIT ON A SMALL OCCUPANT, DO NOT USE THE BELT! YOU NEED A MODEL WITH A SHORTER FIXED LENGTH SIDE.**
9. If sister hooks are used to attach the belt to the vehicle, line up the holes in the hook bodies and secure the two pieces together with the cotter pins provided.

IF THE BELT INCLUDES A SHOULDER HARNESS:

1. Locate a suitable point in the roof, wall, or door post that is above and behind the shoulder point of the seated occupant. (See FIGURE 4)
2. Drill the required holes and install the attachment hardware using the washers and reinforcement plates furnished.
3. The upper harness fitting may be mounted to a suitable reinforced attachment point located in the shaded region in FIGURE 4 labeled "ACCEPTABLE RANGE". Always look for and use factory installation points when available.

UNIVERSAL INSTALLATION IN TRUCKS AND BUSES:

1. Seat belts should not be attached to the seat itself unless the vehicle manufacturer indicates that the seat and its mounting system have been specifically designed to withstand the required loads.

A SUSPENSION SEAT MUST HAVE SEAT TO FLOOR TETHERS. ALWAYS ADJUST THE TETHERS ACCORDING TO THE SEAT OR VEHICLE MANUFACTURER'S RECOMMENDATIONS.

UNIVERSAL INSTALLATION ON PASSENGER BENCH SEATS:

1. Use factory installation points on seat frames only when frames were designed for such assembly.
2. Mount the short end of the belt on the aisle side.
3. Avoid rough or sharp edges when choosing a belt path.
4. **CAUTION: IF THE FIXED END OF A SINGLE SIDE ADJUSTABLE BELT IS TOO LONG TO ALLOW A SNUG FIT ON A SMALL OCCUPANT, DO NOT USE THE BELT! YOU NEED A MODEL WITH A SHORTER FIXED LENGTH SIDE.**
5. Never bolt both ends of the same lap belt to one attachment point. The lap belt should form a "d" shaped loop when in use.
6. Reuse factory mounting bolts or use 7/16 UNF 20 bolts with a minimum rating of grade 5.

